

Insulated Banana Jacks

In-line Banana Jack

- This fully insulated banana jack is designed for secure cable mount via solder or crimp assembly.
- The machined brass body is tin plated for maximum ease of lead-free solderability. This banana jack is fully insulated with nylon 6/6 cap and handle; available in red and black.
- This design is suitable for test lead or patch cord extension where long leads are required. Accepts standard banana plugs.
- Rating: 15 AMPS AC for 10 (degrees symbol) C continuous temperature rise, continuous duty. Voltage 1KVAC.

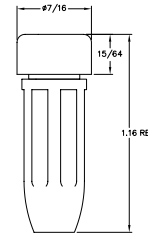

PART NO.	TYPE	HEAD DIA.	HEAD HEIGHT	BODY LENGTH	THREAD	I.D.	INSULATING MATERIAL
251	In-Line	7/16	15/64	29/32	1/4-32	.161	Nylon

Uninsulated Banana Jacks

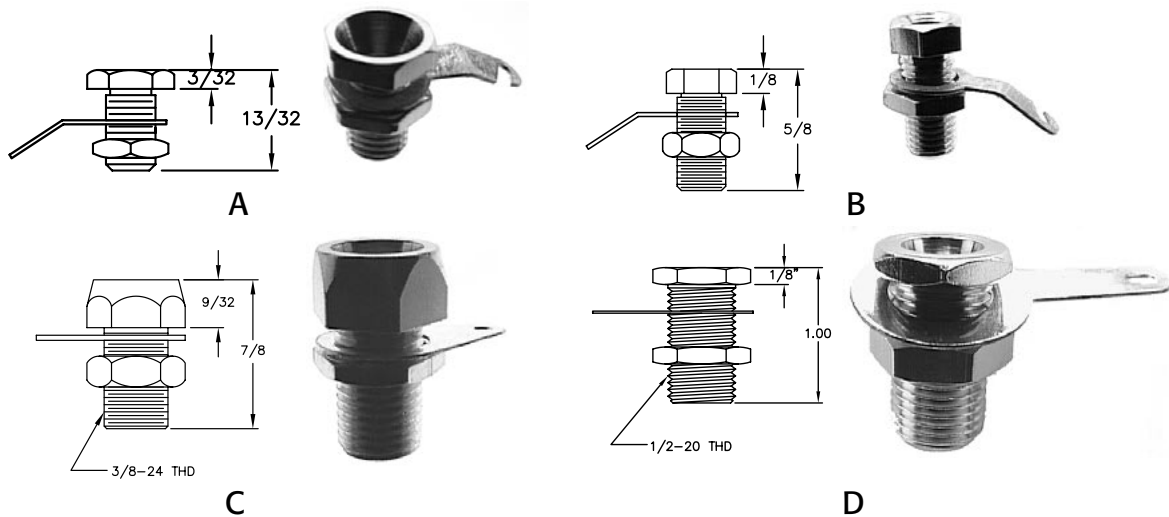

- Threaded bodies are machined from brass and nickel plated.
- Body is held to panel with nut. Wire solders to lug between nut and panel. Hardware included.

PART NO.	ILLUS.	TYPE	HEAD DIA.	HEAD HEIGHT	BODY LENGTH	THD.	I.D.
101	A	Standard	3/8	3/32	13/32	1/4-32	.161
109	B	Standard	5/16	1/8	1/2	1/4-32	.161
187	C	Giant	1/2	9/32	19/32	3/8-24	.275
157	D	Giant	5/8	1/5	7/8	1/2-20	.275